

Mechanical Protection
BAM FS-XE-005-M8-2-01F
Order Code: BAM025W

BALLUFF

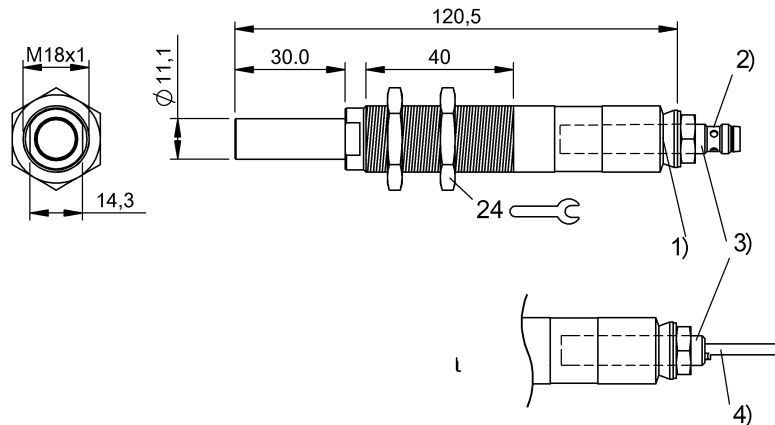

1) Leakage hole, 2) Detail of connector installation, 3) Not included in scope of delivery, 4) Cable attachment detail

Basic features

Scope of delivery	Plunger probe housing Flat tip 2x nut M18x1 3x springs (soft, medium, hard)
Short description	Spare parts set for plunger probe
Use	for positive stop plunger probe

Material

Housing material	Brass, Chrome-plated Steel, Stainless steel, Bronze, Chrome-plated
Material	Brass Bronze Stainless steel Steel
Surface protection	Chrome-plated

Environmental conditions

Ambient temperature	0...60 °C
----------------------------	-----------

Mechanical data

Clamping system	Threads
Dimension	Ø 18 x 120.5 mm
Life expectancy mechanical	1 mil. switching operations
Mounting part	Threads
Size	M18x1
Spring deflection	30 mm
Spring force	27.04 N
Tightening torque max.	35 Nm

Remarks

Spring rate: low = 0.172 N/mm medium = 0.665 N/mm high = 0.980N/mm
 Replacement parts available separately: 3 x spring set (light, medium, heavy)- BAM FS-XE-005-M8/RK2 3 x spring set, washer, round point BAM FS-XE-005-M8/RK1 3 x spring set, washer, flat point BAM FS-XE-005-M8/RK3 3 x spring set, washer, chisel point - BAM FS-XE-005-M8/RK4 3 x spring set, washer, threaded point BAM FS-XE-005-M8/RK5
 Available only as SET products: SET0169 BAV BP-PH-00101-01 contains: 1 pc. BAM FS-XE-005-M8-2-01F (flat point) 1 pc. BES M08MI-PSC40B-S49G
 SET016A BAV BP-PH-00101-02 contains: 1 pc. BAM FS-XE-005- M8-2-01F (flat point) 1 pc. BES M08MI-PSC40B-BP00,2-GS04 SET017Y BAV BP-PH-00101-11 contains: 1 pc. BAM FS-XE-005-M8-2-01F (flat point) 1 pc. BES M08MI-NSC40B-S49G SET017Z BAV BP-PH-00101-12 contains: 1 pc. BAM FS-XE-005- M8-2-01F (flat point) 1 pc. BES M08MI-NSC40B-BP00,2-GS04